

## IB-JXK50 CURRENT TRANSDUCER

### PRODUCT OVERVIEW

The current transmitter is a device that converts large current signals from the field into standard process signals and RS485 digital signals for measuring sine wave AC current signals in industrial fields.

### KEY FEATURES

- 1) Input overload protection
- 2) Output overcurrent limit protection
- 3) Output current short-circuit protection
- 4) Wide voltage power supply
- 5) Working power reverse protection
- 6) Light weight and easy installation
- 7) High precision, good linearity
- 8) Wide frequency band, low temperature drift,
- 9) Fast response, strong anti-interference ability



### PRODUCT PARAMETERS

Installation method	: Standard guide rail (35mm)
Original measurement range	: 0A~150A
Rated output	: 0-5V, 0-10V, DC4-20mA, DC0-20mA, RS485
Load capacity	: 5mA
Linearity	: 0.5%
Accuracy	: 0.5% 1%
Isolated voltage	: 2.5kV/50Hz, 1Min
Temperature drift	: <500PPM/°C
Band width	: DC~20KHZ
DI/DT Follow	: >50A/uS
Consumption current	: 10mA+ output current
Response time	: <200ms
Operating temperature	: -10°C~+70°C
Storage temperature	: -25°C~+85°C
Power supply	: DC24V/AC220V

## PRODUCT SIZE

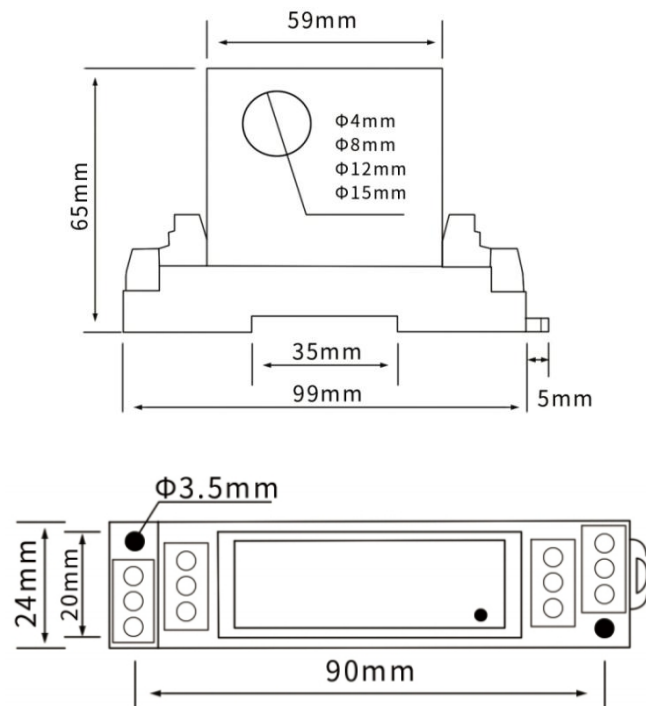

## PRODUCT WIRE

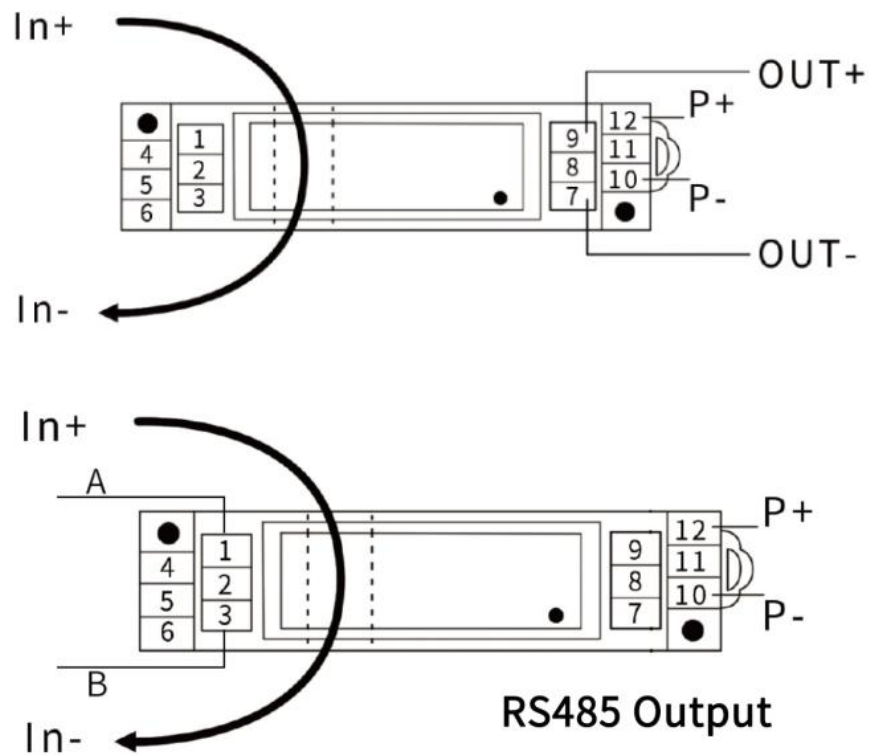

- The power supply must be connected in strict accordance with the wiring diagram.
- Thread directions Punch holes in the direction of the arrow marked on the product.

## INSTALLATION & SAFETY PRECAUTIONS

- 1) Before using the current transmitter, carefully check and confirm the quantity, model and
- 2) specification of the product according to the packing list and product label, and carefully read
- 3) the operation manual of the current transmitter.
- 4) The use environment of the current transformer transmitter should be free of conductive
- 5) dust, corrosive gas, strong impact and vibration.
- 6) The integrated structure of the current converter transmitter is not removable, and collision
- 7) and fall should be avoided. Do not alter or tear any label on the product.
- 8) When the current transmitter is installed centrally, the installation spacing is usually  $>10\text{mm}$ .
- 9) When using, wiring must be strictly in accordance with the wiring method in the instruction manual, and then switch on the power and signal after checking.

- Website: <http://www.qd-zdk.com>
- 400 number: 400-127-7889
- Landline number: 0561-3033839

## RS485 Communication Protocol

### 1. Physical interface and functional features:

- 1.1 RS485 is used for serial communication.
- 1.2 The transmission mode is half-duplex asynchronous. The start bit is 1 bit, the data bit is 8 bit, and the stop bit is 1 bit.
- 1.3 The default address is 01H and the default baud rate is 9600bps.
- 1.4 In the bus equipment, this sensor is a slave, current (or voltage) input, standard RS-485 digital interface output, to achieve the interconnection with computers or other upper computers, widely used in power, communication, transportation, environmental protection, petrochemical, steel and other fields, used to detect the current or voltage consumption of AC and DC equipment.
- 1.5 Adopt industrial-grade imported chip professional algorithm, high precision.
- 1.6 With automatic thermal shutdown and ESD protection functions
- 1.7 A variety of power supply methods can be selected DC12V, DC15V, DC24V, 220V and so on.
- 1.8 A variety of installation methods are available, including standard rail installation, flat screw fixing, detachable split structure, PCB welding installation, etc.
- 1.9 New electromagnetic isolation, photoelectric isolation technology, low power consumption.
- 1.10 The average working time is greater than 100,000 hours, and the working environment temperature is -20°C ~ 80°C
- 1.11 Support input range, output type, working power supply three parameters of the special customization.

### 2, Read data command example:

#### 2.1 Single-input Transmitter COMMAND(down-pass command) :

Slave address	Function code	Data start (H)	Data start (L)	Number of data (H)	Number of data (L)	CRC-L	CRC-H
01H	03H	00H	0EH	E5H	00H	01H	C9H

#### RETURN(return information) :

Slave address	Function code	Data length	Data H	Data L	CRC-L	CRC-H
01H	03H	02H	08H	CBH	FEH	13H

2.1.1 Specifies that the range ≤300 is reserved for two decimal places, and > 300 is reserved for one decimal place.

#### 2.1.2 Communication Example (Reading PV) :

Example 0-30A(V) transmitter communication device address 1, i.e. (address range 1-255)

CRC check =E5 C9. Send and return the following data:

Send: 01 03 00 0E 00 01 E5 C9

Return: 01 03 02 05 DC BA 8D

Data 05 DC hexadecimal conversion to 1500 (two decimal places reserved)

Therefore, the current value is 15.00A (in A)

### 3. Modify address (station number) command example (function code is 06) : (Slave address is changed from the current ADD1 to ADD2)

#### COMMAND(send down command) :

Slave address	Function code	Start register address	Write register data	CRC-L	CRC-H
01H ADD1	06H	00H	04H 02H (ADD2)	49H	CAH

#### RETURN(return information) :

Slave address	Function code	Start register address	Write register data	CRC-L	CRC-H
01H ADD1	06H	00H	04H 02H (ADD2)	49H	CAH

#### Example of modification:

For example, change the address 01 to 02

Send: 01 06 00 04 00 02 49 CA

Back to: 01 06 00 04 00 02 49 CA

The original address 01 is successfully changed to 02

#### Instructions:

3.1, the above command ADD1 is the original address number of the transmitter, ADD2 is the address number to be changed. Change the address needs to be powered off and restarted to make it effective

3.2. The factory default address of the sensor is 01H, and the range of ADD1 and ADD2 can be set is 00 to FEH. A total of 255 addresses can be modified. Note that the user cannot change the address to FFH.

### 4, modify the baud rate command example (function code is 06) : (change the baud rate to 4800bps)

#### Description: COMMAND(down command) :

Slave address	Function code	Start register address	Data to be written to a register	CRC-L	CRC-H
01H	06H	00H	05H 00H 30H	99H	DFH

#### RETURN(return information) :

Slave address	Function code	Start register address	Data to be written to a register	CRC-L	CRC-H
01H	06H	00H	05H 00H 30H	99H	DFH

#### Example of modification:

For example, change the baud rate from 9600bps to 4800bps

Send: 01 06 00 05 00 30 99 DF

Back: 01 06 00 05 00 30 99 DF

Change the baud rate from 9600bps to 4800bps. After the change takes effect, power off and save the Settings

#### 4.1 The list of baud rate commands is as follows:

Baud rate	1200	2400	4800	9600	19200	38400	57600	115200
Code	CH	18H	30H	60H	C0H	180H	240H	480H

### 5, Read the transmitter address and baud rate command example (function code is 03)

#### COMMAND(send down command) :

Slave address	Function code	Start register address	Register count	CRC-L	CRC-H
01H	03H	00H	04H 00H 02H	85H	CAH

#### RETURN(return information) :

Slave address	Function code	Register count	Current slave address	Current slave baud rate	CRC-L	CRC-H
01H	03H	04H 00H	01H	00H 60H	ABH	DBH

#### Example of modification:

For example: read the transmitter address and baud rate

Send: 01 03 00 04 00 02 85 CA

Return: 01 03 04 00 01 00 60 AB DB

Note: In the data frame returned after the transmission command is sent (marked in blue) : 01H is the address of the current slave, 60H is the baud rate of the current slave 9600bps (baud rate code see article 4).

### 6. Message format

#### 6.1 Function code 03H: Queries slave register data

##### Host packet (downpass)

Slave address	1 byte (00H~FFH)
Function code	1 byte (03H)
Start register address	2 bytes
Register count	2 bytes
CRC check code	2 bytes

##### Slave message

Slave address	1 byte (00H~FFH)
Function code	1 byte (03H)
Data bytes	1 byte
Data area	2* Register number bytes/register content
CRC check code	2 bytes

#### 6.2 Function Code 06H - Number of slave machines

##### Host packet (downpass)

Slave address	1 byte (00H~FFH)
Function code	1 byte (06H)
Register address	2 bytes
Writes data to a register	Bytes =2 x number of registers
CRC check code	2 bytes

##### Slave message

Slave address	1 byte (data written to the register)
Function code	1 byte (06H)
Register address	2 bytes
Register count	2 bytes
CRC check code	2 bytes

### 7. Register description

#### 7.1 Single power input register definition table

Register address	Register content	Register count	Register status	Data range
000EH	Single circuit capacity	1	Read only	- 32767 ~ + 32767

#### 8.3 Definition table of address and baud rate registers

Register address	Register content	Register count	Register status	Data range
0004H	Address	1	Read-write	00H~FEH
0005H	Baud rate	1	Read-write	CH~480H

### 8. Sensor and computer connection diagram:

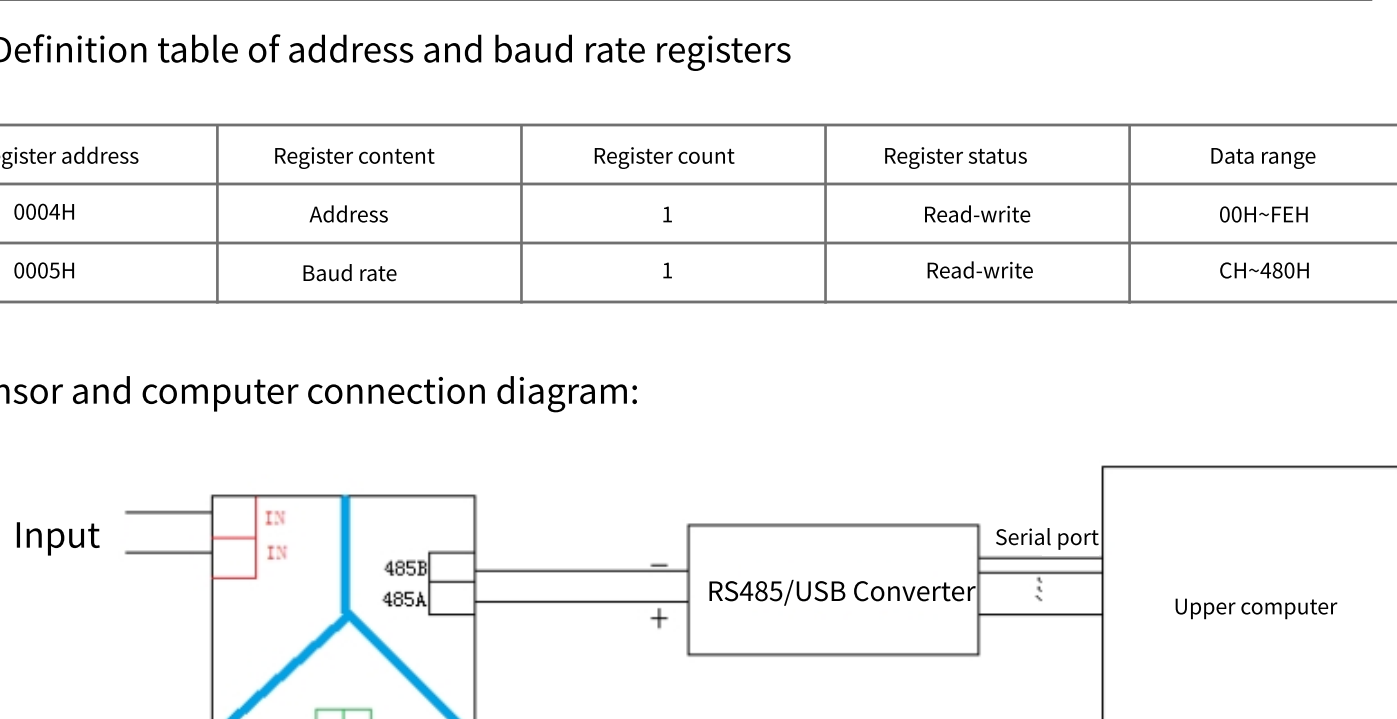

### 9. Example application

Model: JXK series

Enter AC0 to 20A

Output: RS485

Power Supply: +24V

Baud rate: 9600bps

Address: 01H

Input and output reference table (theoretical values) :

	Current Input	Output	Output (decimal)	Actual current value (keep 2 decimal places)
		(A/D-H+A/D-L)		
0%	0	0000H	0	0
20%	4	018FH	399	3.99
40%	8	0320H	800	8.00
60%	12	04B1H	1201	12.01
80%	16	0642H	1602	16.02
100%	20	07D0H	2000	20.00

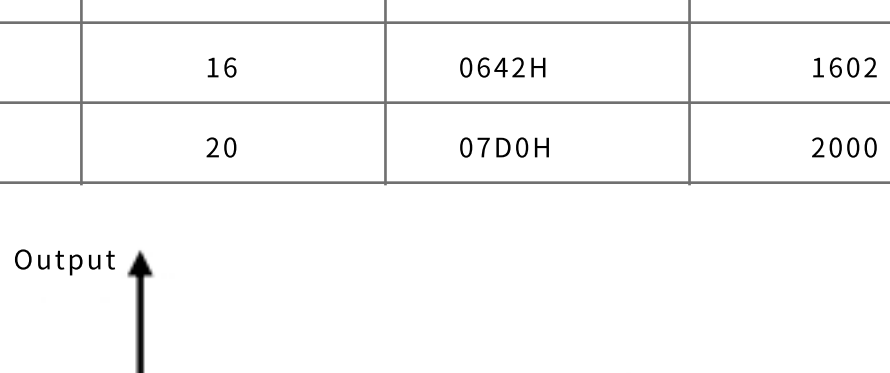

Read data instruction: 01 03 00 0E 00 01 E5 C9

Read baud rate and address instruction: 01 03 00 04 00 02 85 CA

Modify address instruction: 01 06 00 04 00 01 09 CB needs to power off and restart

Modify the baud rate command: 01 06 00 05 00 01 58 0B Power off and restart